

**Report on test in accordance with  
OECD STANDARD CODE II for the Official  
Testing of Agricultural Tractor Performance**



Restricted Code

OECD No.

**1680**



**Agricultural Tractor  
CASE IH MX110 - MAXXUM (4WD)  
40 km/h-version, Power Shift  
Model denomination MX110**

**Manufacturer**

CASE United Kingdom Limited  
Wheatley Hall Road  
Doncaster DN2 4PG, England

This is a report on a tractor test in accordance with OECD STANDARD CODE for the Official Testing of Agricultural Tractor Performance (C(87)53(Final), CODE II) and amendments (C(90)79, C(92)52, C(93)52 and C(93)133).

It does not contain an evaluation of the tractor on practical work.

Duration of tests: November 1996 till June 1997

DLG-Testing Station for Agricultural Machinery, Max-Eyth-Weg 1,  
D-64823 Groß-Umstadt

This report has been approved by the OECD Co-Ordinating Centre (CEMAGREF, France) as being in accordance with the OECD STANDARD CODE.

Date of approval: 3rd October 1997

OECD No. 1680  
Restricted Code

---

In this report all performance characteristics are given corresponding to the International System of Units.

The reference to the former used Technical System of Units is given by the following relations:

Forces	1 kN	=	1000 N	=	102 kp
Powers			1 kW	=	1,36 PS
Pressures	1 MPa	=	10 bar	=	10,2 kp/cm <sup>2</sup>
	100 kPa	=	1000 mbar	=	750,10 mm Hg

---

All rights including the right of translation, reprint and photo-mechanical copying – also of excerpts – reserved by the editor.

Printed in Germany, December 1997  
DLG-No. 295

## TABLE OF CONTENTS

	Page
<u>SPECIFICATION OF TRACTOR</u>	4 to 19
<u>TEST CONDITIONS</u>	19 to 21
<u>COMPULSORY TESTS</u>	
1 Main power take-off performance	22 to 25
2 Hydraulic power and lifting force	26 and 27
3 Drawbar power and fuel consumption	28 and 29
4 Repairs and remarks	30

**CASE IH MX110 - MAXXUM (40 km/h), Power Shift**

**Test No. 97-159**

Tractor manufacturer:	CASE United Kingdom Limited Doncaster DN2 4PG, England
Location of tractor assembly:	Doncaster DN2 4PG, England
Submitted for test by:	CASE Germany GmbH, D-41460 Neuss
Selected by:	Manufacturer with agreement by DLG
Place of running-in:	Doncaster and Groß-Umstadt
Duration of running-in:	Engine and tractor 104 hours

## SPECIFICATION OF TRACTOR

### Tractor

Make:	CASE IH
Trade name:	MX110 MAXXUM (4WD), 40 km/h version, Power Shift
Model denomination:	MX110
Type:	Wheel tractor, semi frame construction, four wheel driven
Serial no.:	JJE 095 0012
1st serial no.:	JJE 095 0001

### Engine

Make:	CDC
Model:	6T-590
Type:	Watercooled 4 stroke Diesel-engine direct injection, supercharged,
Serial no.:	453 368 18/1
Cylinders:	6, in line, bore 102 mm, stroke 120 mm, displacement 5883 cm <sup>3</sup> ; compression ratio 17.5 ± 1.5 : 1;
Valves:	Overhead

### Supercharging

Make:	HOLSET
Model:	HX35
Type:	Exhaust driven supercharger, non wastegate without intercooler
Max. pressure:	91 ± 15 kPa

- Fuel system:** FEDERAL MOGUL fuel supply pump,  
BOSCH (optional MICO, Lic. BOSCH) inline "A" injection pump  
Type PN 3932411 (CDC Part No.)  
serial no.: 56928684  
manufacturer's production setting  
63.0 ± 2 mm<sup>3</sup>/stroke at maximum power at 2000 rev/min,  
57.0 ± 2 mm<sup>3</sup>/stroke at full load and rated speed;  
static injection timing device,  
14° ± 1° crank angle before TDC;  
BOSCH multihole injection nozzles;  
injection pressure 24 + 1.0 MPa;  
replaceable fuel filter;  
capacity of fuel tank 263 dm<sup>3</sup>
- Governor:** BOSCH mechanical RSV governor,  
without supercharge pressure compensating device,  
governed range of engine speed 925 ± 100 to 2420 +0/-50  
rev/min,  
rated engine speed 2200 rev/min
- Air cleaner:** DONALDSON, 141568A\*, aspirated,  
Optional: 141567A\*, non-aspirated;  
dry paper element filter with precleaner, safety element,  
replaceable cartridge; electric warning indicator lamp;  
air intake below bonnet, behind front grille
- Exhaust silencer:** DONALDSON, 220159A\*, aspirated,  
Optional DONALDSON or NELSON, 220158A\* non-aspirated;  
multi-chamber expansion-type muffler  
140 mm dia, 1790 mm long, located by RH "A" post; mouth  
showing forward to the right, top 2970 mm above ground
- Lubrication system:** Pressure lubrication, internal gear pump,  
full flow oil filter with replaceable cartridge,  
engine oil/cooling-water heat exchanger in crankcase
- Cooling system:** Water cooling with impeller pump,  
overpressure relief valve set to 103 + 7 kPa;  
thermostat and by-pass circuit;  
ECS / EATON 188922 A \*  
viscous drive fan, belt driven, variable fan speed controlled  
by air flow temperature,  
7 blades with 580 mm dia;  
water capacity 20 dm<sup>3</sup>

- Starting system: Electrical;  
NIPPONDENSO or BOSCH solenoid pre-engaged drive starter motor 3.1 kW;  
cold starting aid: Flame plug in air intake channel  
optionally: Ether injection to air intake manifold
- Safety device:  
Forward/neutral/reverse lever in neutral position  
Operator Presence Control
- Electrical system: 12 Volt, negative earth;  
BOSCH 3-phase alternator K1-14 V/95A 1330 W;  
2 lead acid batteries, 105 Ah, at 20 hours discharge period, each

## Transmission

Universally jointed propeller shaft between engine and gear box

- Clutch (travel alone): CASE France  
wet multi-plate clutch, 127 mm dia, hydraulically operated by pedal or electro-hydraulically controlled by forward/neutral/reverse lever, integrated in gear box
- Gear box: CASE France, mechanical, POWER SHIFT, 40 km/h version;  
power shift speed change gear with 4 speeds;  
range gear with 4 synchronized ranges, (I, II, III, IV);  
2 wet multi-plate clutches shift reversing gear (power shifted), range IV locked out in reverse operation;  
total number of gears: 16 forward, 12 reverse;  
2 levers, 1 switch
- optionally available, not fitted:  
1 synchronized creeper range (CR), acting on all range gears;  
provides total 32 forward and 24 reverse speeds
- Rear axle and final drives: CASE France, bevel gear drive;  
bevel gear differential with multiplate differential lock, electro-hydraulically engaged/disengaged by switch or automatically disengaged by service brake operation or engine cutoff;  
planetary final drives
- Front axle and final drives: CARRARO 20.19;  
driven by wet multi-plate clutch, propeller shaft (in tractor's median plane) and bevel gear;  
clutch operated by electro-hydraulic switch;  
limited slip differential;  
planetary final drives

Total ratios and speeds:

Number of revolutions of front wheels for one revolution of rear wheels: 1.3199

Range	Gear	Number of engine revolutions for one revolution of the driving wheels	Nominal travelling speed *) at rated engine speed 2200 rev/min km/h
<b>Forward speeds</b>			
I	1	246.82	2.87
	2	204.93	3.46
	3	165.81	4.28
	4	133.85	5.30
II	1	108.29	6.55
	2	89.91	7.89
	3	72.75	9.75
	4	58.73	12.07
III	1	65.87	10.77
	2	54.69	12.97
	3	44.25	16.03
	4	35.72	19.85
IV	1	33.88	20.93
	2	28.12	25.22
	3	22.75	31.17
	4	18.37	38.61
<b>Reverse speeds</b>			
I	1	213.31	3.32
	2	177.11	4.00
	3	143.30	4.95
	4	115.68	6.13
II	1	93.61	7.58
	2	77.71	9.12
	3	62.88	11.28
	4	50.75	13.97
III	1	56.94	12.45
	2	47.27	15.00
	3	38.25	18.54
	4	30.87	22.97

\*) calculated with the radius index (ISO 4251/1-1992) 855 mm

**Main p.t.o.:** Independent;  
 driven by wet multi-plate clutch;  
 electro-hydraulically operated, electronically controlled by lever;  
 1 reversible shaft at tractor's rear  
 2 speeds selectable by hand lever  
 35 mm dia, 6 splines, ISO 500-1991 type 1  
 35 mm dia, 21 splines, ISO 500-1991 type 2

754 mm above ground, 500 mm behind rear wheel centre;  
 direction of rotation clockwise, seen in direction of travel

p.t.o. type	p.t.o. speed rev/min	engine speed rev/min	p.t.o. transmission ratio	power restriction kW
1000	1000	2209	2.2095	-
	996	2200		
540	540	1875	3.4720	-
	634	2200		

**Secondary p.t.o.** Front p.t.o., independent  
 driven by wet multi-plate clutch and gear box from front end of engine crankshaft,  
 electro-hydraulically operated by switch  
 1 speed (1000 rev/min),  
 1 shaft 35 mm dia, 6 splines, ISO 500-1991 type 1

840 mm above ground, 715 mm in front of front wheel centre,  
 direction of rotation clockwise, seen in direction of travel

p.t.o. type	p.t.o. speed rev/min	engine speed rev/min	p.t.o. transmission ratio	power restriction kW
1000	1000	2000	2.000	-
	1100	2200		

Power lift

**CASE;**  
electro-hydraulic power lift, unit construction, draft, position-  
and intermixable control, floating position, fast raising,  
lowering throttle, lower links' sensing

Hydraulic system:

Closed, load sensing, pressure and flow compensated system;  
VICKERS variable displacement axial-piston pump, driven  
by gearbox, max. delivery 109 dm<sup>3</sup>/min at rated engine speed,  
oil cooler in front of engine coolant radiator,  
oil filter in feed line;

VICKERS control valve,  
relief valve pressure setting  $20.2 \pm 0.4$  MPa;  
single acting cylinder with 105 mm bore and  
227 mm stroke, safety valve set to  $23.5 \pm 0.7$  MPa;

3 double acting additional CASE control valves,  
one valve used for front power lift, 4 oil couplings  
at rear of tractor;  
maximum volume of oil, available to external cylinders :

stationary tractor operating on slopes of no more than 2 degrees	30 dm <sup>3</sup> ,
moving tractor operating on slopes of no more than 15 degrees	20 dm <sup>3</sup> ,
of no more than 30 degrees	12 dm <sup>3</sup> ;

hydraulic oil reservoir in common with gear box with  
76 dm<sup>3</sup> capacity (88 dm<sup>3</sup> capacity with increased oil level)

the hydraulic oil pump further provides hydraulic pressure for  
actuating of steering, p.t.o clutch, power-shift gear, rear axle  
differential lock and for shifting the front axle drive clutch

Three-point linkage: Category 2 acc. to ISO 730/1-1994,  
lower links with WALTERSCHEID quick couplers

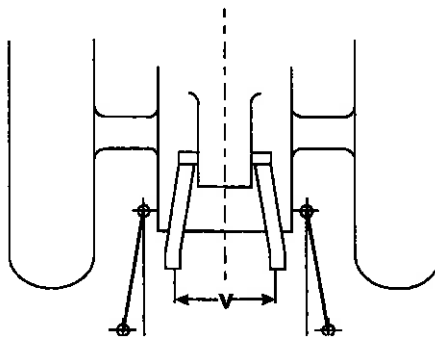
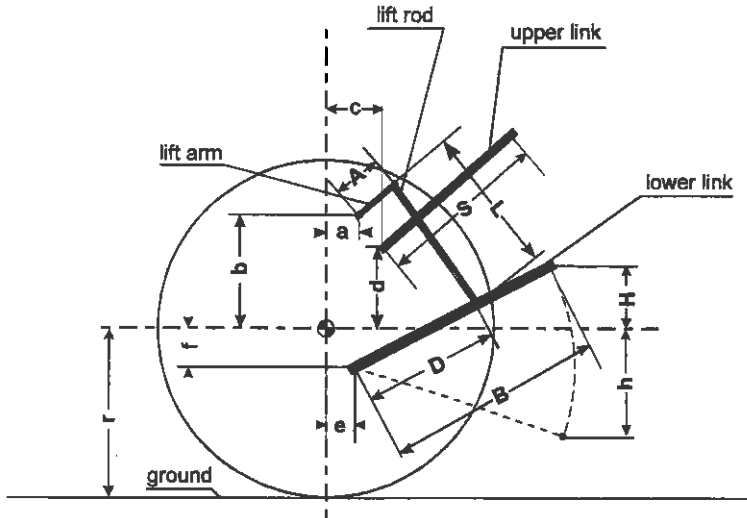

Dimensions of rear implement linkage			projected lengths in mm	
			dimensions (general)	dimensions used for test
Rear tyres 20.8 R 38 radius index *)	(r)*	855		
Front tyres 16.9 R 28 radius index **)	(r')*	670		
Length of lift arms	(A)	230		
Length of lower links	(B)	891		
Distance of lift arm pivot points from rear axle centre	horizontal (a)	249		
	vertical (b)	173		
Horizontal distance between lower link pivot point	(u)	543		
Horizontal distance between lift arm end points	(v)	692		
Length of upper link	(S)	610-880		760
Distance of upper link pivot point from rear wheel axis	horizontal (c)	342,366		366
	vertical (d)	284,219		219
Distance of lower link pivot point from rear wheel axis	horizontal (e)	223		
	vertical (f)	253		
Distance of lower link pivot point from lift rod pivot points on lower links	(D)	554		
Length of lift rods	(L)	525-642		642
Height of lower link hitch points relative to rear wheels' centre line (situated 855 mm above ground), these data are valid for unloaded power lift:				
Length of lift rods	(L)	525		642
Linkage distance of lift rods	(D)		554	
Lowest position	(h)	378		655
Highest position	(H)	200		100
Transport position	(H')	200		100

\*) Assuming r resp. r' = tyre dynamic radius index of ISO 4251/1-1992

Front power lift:

Three point linkage

Category 2 acc to ISO 730/1 - 1994,  
lower links with WALTERSCHEID quick couplers

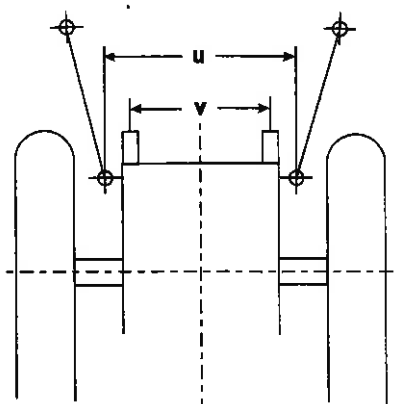
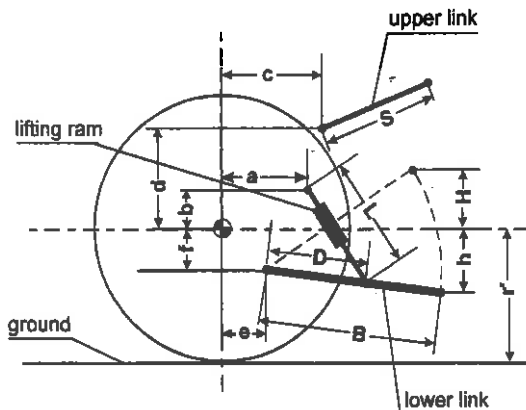

Dimensions of front implement linkage		projected lengths in mm	
		dimensions (general)	dimensions used for test
Rear tyres, 20.8 R 38, radius index	(r)*	855	
Front tyres, 16.9 R 28, radius index	(r')*	670	
Length of lower links	(B)	710	
Distance of lifting ram pivot point from front wheel axis	horizontal (a)	440	
	vertical (b)	326	
Distance of upper link pivot point from front wheel axis	horizontal (c)	750, 725	750
	vertical (d)	505	
Distance of lower link pivot point from front wheel axis	horizontal (e)	600	
	vertical (f)	85	
Horizontal distance between lower link pivot points	(u)	621	
Horizontal distance between lifting ram pivot points	(v)	380	
Distance of lower link pivot point from lifting ram fixing point on lower link	(D)	200	
Length of lifting ram	min./max. (L)	335 - 535	
Length of upper link	min./max. (S)	490 - 650	565
Diameter of lifting ram		63	

Height of lower link hitch points relative to front wheel axis (situated 670 mm above ground), these data are valid for unloaded power lift

Lowest position	(h)	450
Highest position	(H)	260
Transport position	(H')	260

\*) Assuming r resp. r' = tyre dynamic radius index of ISO 4251/1-1992

### Pull equipment

Swinging drawbar:	not fitted to tested tractor	
	Longitudinally adjustable	
	height above ground	433 mm
	distance of hitch point	
	from rear wheel axis,	
	horizontally	895, 945, 1045, 1145 mm
	from p.t.o. shaft end	
	vertically	321 mm
	horizontally	395, 445, 545, 645 mm
	pin hole swingable to both sides of centre line (6° or 11°)	
	with drawbar fully pushed in	101/184 mm
	with drawbar fully drawn out	127/218 mm
	distance of pivot point from rear wheel axis	
	horizontally (before axis)	73 mm
	diameter of drawbar pin hole	33 mm
	maximum vertical permissible load	
	(drawbar fully pushed in)	18 kN
Trailer hitch:	CRAMER, KU 64002 A, automatic	
	diameter of hitch pin	32 mm
	height above ground adjustable by one hand	
	quick adjustment to	803, 852, 901, 950, 999 mm
	distance of hitch point	
	from rear wheel axis, horizontally	688 mm
	from p.t.o. shaft end,	
	horizontally	188 mm
	vertically	49, 98, 147, 196, 245 mm
	maximum vertical permissible load	20 kN
Hitch hook:	fitted to tested tractor	
	DROMONE Eng. Ltd, Type A 3200	
	hydraulically operated, hook interchangeable with drawbar,	
	distance of hitch point from rear wheel axis,	
	horizontally	560, pushed out 825 mm
	from p.t.o. shaft end	
	vertically	240 mm
	horizontally	60, pushed out 325 mm
	maximum vertical permissible load	30 kN
Holed drawbar:	short bar, length between ball guides	820 mm
	9 holes with 33 mm diameter with 80 mm distance each	
	thickness	30 mm
	height above ground:	
	maximum	1055 mm
	minimum	200 mm
	horizontal distance to p.t.o. shaft end (with lower links horizontal)	614 mm
Towing hitch:	At front, height of mouth's centre above ground	1020 mm

## Steering

DANFOSS, Dual displacement, OSPD 60/185 LS; or  
EATON, 263-4325-002  
hydrostatic front wheel steering, connected by sequence valve  
to the hydraulic system of the tractor (see on page 9);  
1 integrated WEBER ram (symmetrical design),  
240 mm stroke, 72 mm bore and 38 mm dia of  
piston rod, directly acting on steering levers,  
working pressure  $18.3 \pm 0.35$  MPa

## Brakes

### Service brake:

CASE  
pedal operated muscle power brake with hydraulic transmission,  
using oil of gearbox, acting on rear wheels;  
front axle drive is engaged automatically during braking;  
oil-immersed disc brake with 1 ring-piston on each  
differential half shaft;  
disc diameter 300 mm  
optionally available: power assisted brakes

### Trailer brake

Compressed air braking system, one line and two line system  
couplings at rear of tractor  
WABCO compressor, belt driven by engine crankshaft

### Parking brake:

Mechanical wet disc brake, operated by lever with ratchet;  
2 lining discs with 143 mm dia each,  
situated on drive shaft of rear axle  
(in front of bevel-gear pair)

### Steering brake:

Divided pedal of service brake,  
for normal use locked together

## Wheels

### Front:

Steering and driving, 2 pneumatics

### Rear:

Driving, 2 pneumatics

### Wheelbase:

2700 mm

### Track width:

At front adjustable from 1530 mm up to 1930 mm  
in steps of 100 mm each by adjustable gauge  
bowl wheels and by turning the wheels  
At rear adjustable from 1530 mm up to 1930 mm  
in steps of 100 mm each by adjustable gauge  
bowl wheels and by turning the wheels

Possible combinations of tyre sizes

Tyre sizes	
Front	Rear
13.6 R 28	16.9 R 38 or 480/70 R 38
420/70 R 28	18.4 R 38 or 520/70 R 38
380/70 R 28	16.9 R 38 or 480/70 R 38
14.9 R 28	18.4 R 38 or 480/70 R 38
16.9 R 28	20.8 R 38
480/70 R 28	20.8 R 38 580/70 R 38

Protective structure

CASE, cab model CASE IH MX30 - EURO-version 2-door, OECD-tested driver's platform with integrated safety frame, OECD approval no. CSS 0387 / 395  
not tiltable, antivibration mounted by silent-blocks on tractor; 2 doors with 3 steps each, steps 532, 804 mm and 1076 mm; driver's platform 1315 mm above ground; windscreen, rear window and rear side windows tiltable; roof hatch, air conditioner (not fitted to tested tractor) and combined heating/ventilation system with 3-step blower and cooling-water heat exchanger incorporated in roof; air intake around side and front roof perimeter, dry air filter; air outlet jets in the roof at front, recirculating louver at rear, defroster nozzles in the roof at front

Noise reduction materials:

Roof, Headliner:	Fabric, acoustical-foam resin impregnated 50/50 cotton felt /fiberglass (moulded part) acoustical-foam	5 - 75 mm 10 - 25 mm 70 mm
Roof, front part:	ABS-panel part	3 mm
Floor:	Mat, consisting of: compression moulded rubber	30 mm
Seat support, on the surface and the front side:	Mat, consisting of: compression moulded rubber	30 mm
Console panels:	Compound mat, consisting of: perforated vinyl and foam ABS backing foam at the cab floor	12 mm 3 mm 25 mm
Rear panel:	None	

Mudguards:	Compound mat, consisting of: perforated vinyl and foam perforated ABS backing acoustical-foam	6 mm 3 mm 25 mm
B-posts:	ABS-panel part	3 mm
Bulk head:	Compound mat, consisting of: foam compression moulded rubber foam with alu foil	12 mm 8 mm 25 mm
Draught proofing:	Rubber seals and Silicon	

Driver's seat

GRAMMER, MSG 95 A/31  
upholstered seat with back rest and arm rests,  
pneumatic suspension with automatic weight  
adjustment, hydraulic shock absorber;  
height of unloaded seat above seat platform  
steplessly adjustable from 410 to 530 mm,  
longitudinal adjustment 215 mm

Operating hours  
meter

Electronic, counts real operating  
hours when engine is running

Lighting

Electrical, 12 Volt,

	Height above ground of centre mm	Size mm	Distance from outside edge of lights to median plane of tractor mm
Headlights	1400	160x80	230
Headlights, 2nd pair	2720	140x75	740
Auxiliary lights	2770	130x75	450
Rearlights	1820	60x50	840
Reflectors	840	100x50	600

TEST CONDITIONS

Overall dimensions

Length without / with front power lift mm	Width mm	Height at top of	
		protective structure mm	exhaust silencer pipe mm
4675 / 5205	2360	2970	2970

Ground clearance: 390 mm underneath hitch hook

Tractor mass

(with cab)

	Without driver kg	With driver kg
Front	2720	2735
Rear	3545	3605
Total	6265	6340

### Tyres and track widths specifications

	Front	Rear
<b>Tyres:</b>	<b>GOODYEAR</b>	<b>GOODYEAR</b>
Dimensions	16.9 R 28	20.8 R 38
ply rating/load index speed index	- / 136 A8	- / 153 A8
type	radial-ply	radial-ply
maximum load (tyre manufacturer's) 40 km/h	2240 kg	3650 kg
inflation pressure (tyre manufacturer's)	160 kPa	160 kPa
radius index	670 mm	855 mm
Chosen track width	1830 mm	1830 mm
Rims	DW15x28	DW 18Lx38
Technically permissible axle load	4500 kg	6600 kg
Technically permissible total weight	9000 kg	

### Oils and lubrication

#### Capacity and change interval:

	Capacity dm <sup>3</sup>	Oil change h	Filter- change h
Engine	15.0	250, 300 with CASE IH oil and filter	
Gearbox, hydraulic system, rear axle and final drives	76.0	1200	1200
Front axle (differential)	6.0		-
Final drives (front)	2 x 0.6		-

**Specification:**

	Recommended	Used during test
<b>Engine oil used in:</b> Engine Type Viscosity Winter Summer Tropics Classification	Engine oil  SAE 10W/30 SAE 15W/40 or 10W/30 SAE 15W/40 API-CE	CASE-IH engine oil no.1 SAE 15W/40   API-CE
<b>Transmission oil used in:</b> Gearbox with rear axle incl. final drives, hydraulic system, steering, brake system Type Viscosity Classification Front axle incl. final drives Type Viscosity Classification	CASE IH HYTRAN-PLUS ISO-VG-46 MS 1223 *)  Gear oil SAE 85W/140 MS 1316 *)	CASE IH HYTRAN-PLUS ISO-VG-46 MS 1223 *)  Gear oil SAE 85W/140 MS 1316 *)

\*) MS = CASE material specification

**Grease:** Multi purpose grease  
 number of lubrication points: 10  
 +4 at front power lift +2 at hitch hook

**Fuel:**

Used during test:

Type: ARAL Diesel fuel, in conformity with DIN 51601

Density at 15° C: at p.t.o. performance tests 0,834 g/cm<sup>3</sup>  
 at drawbar power tests 0,847 g/cm<sup>3</sup>

According to tractor manufacturer also permitted:

Rape seed oil fuel (methyl ester RME)

### COMPULSORY TESTS

#### 1. MAIN POWER TAKE OFF PERFORMANCE (1000 rev/min)

Date of tests: 22nd May 1997  
 Location of tests: DLG-Testing Station Groß-Umstadt  
 Type of dynamometer: SCHENCK hydraulic dynamometer U1-40

Power kW	Speed		Fuel consumption			Specific energy kWh/dm <sup>3</sup>
	Engine rev/min	P.t.o. rev/min	hourly dm <sup>3</sup> /h	kg/h	specific g/kWh	

#### Maximum power

##### 1.1 At 2-hour test

74.7	1950	883	21.56	17.98	240	3.46
------	------	-----	-------	-------	-----	------

##### 1.2 At rated speed

72.4	2200	996	22.61	18.86	260	3.20
------	------	-----	-------	-------	-----	------

##### 1.3 At standard p.t.o. speed

72.4	2200	996	22.61	18.86	260	3.20
------	------	-----	-------	-------	-----	------

#### 1.4 Part loads, the governor hand lever in the position corresponding to maximum power at full load (curve a)

##### 1.4.1 the torque corresponding to maximum power at rated speed

72.4	2200	996	22.61	18.86	260	3.20
------	------	-----	-------	-------	-----	------

##### 1.4.2 85% of the torque obtained in 1.4.1

64.3	2297	1040	21.26	17.73	275	3.02
------	------	------	-------	-------	-----	------

##### 1.4.3 75% of the torque defined in 1.4.2

48.7	2326	1053	17.89	14.92	305	2.72
------	------	------	-------	-------	-----	------

##### 1.4.4 50% of the torque defined in 1.4.2

32.9	2357	1067	14.47	12.07	366	2.27
------	------	------	-------	-------	-----	------

##### 1.4.5 25% of the torque defined in 1.4.2

16.7	2392	1083	10.86	9.06	540	1.54
------	------	------	-------	------	-----	------

##### 1.4.6 unloaded

-	2423	1097	7.39	6.17	-	-
---	------	------	------	------	---	---

Power kW	Engine rev/min	Speed P.t.o. rev/min	Fuel consumption		specific g/kWh	Specific energy kWh/dm <sup>3</sup>
			hourly dm <sup>3</sup> /h	kg/h		

1.5 Part loads, the governor hand lever in the position corresponding to standard p.t.o. speed at full load (curve b)

1.5.1 the torque corresponding to maximum power

72.4	2200	996	22.61	18.86	260	3.20
------	------	-----	-------	-------	-----	------

1.5.2 85% of the torque obtained in 1.5.1

64.3	2297	1040	21.26	17.73	275	3.02
------	------	------	-------	-------	-----	------

1.5.3 75% of the torque defined in 1.5.2

48.7	2326	1053	17.89	14.92	305	2.72
------	------	------	-------	-------	-----	------

1.5.4 50% of the torque defined in 1.5.2

32.9	2357	1067	14.47	12.07	366	2.27
------	------	------	-------	-------	-----	------

1.5.5 25% of the torque defined in 1.5.2

16.7	2392	1083	10.86	9.06	540	1.54
------	------	------	-------	------	-----	------

1.5.6 unloaded

-	2423	1097	7.39	6.17	-	-
---	------	------	------	------	---	---

No load maximum engine speed:	2423 rev/min
Equivalent flywheel torque at rated engine speed:	314 Nm
Equivalent flywheel torque at 2-hour test:	366 Nm
at engine speed:	1950 rev/min
Maximum equivalent flywheel torque:	457 Nm
at engine speed:	1100 rev/min

Mean atmospheric conditions

temperature:	24 °C
pressure:	99.3 kPa
relative humidity:	45 %

Maximum temperatures

coolant:	80 °C
oil:	108 °C
fuel:	45 °C
air intake:	25 °C

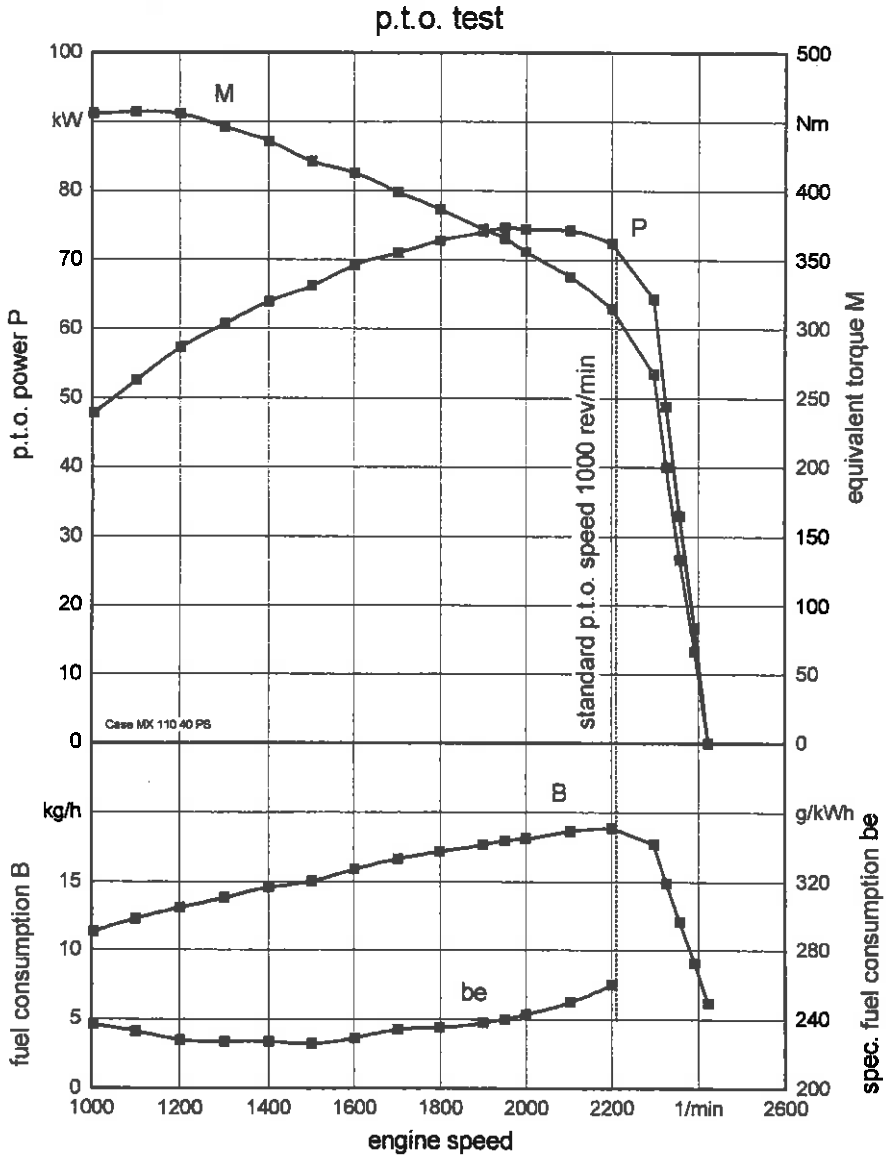

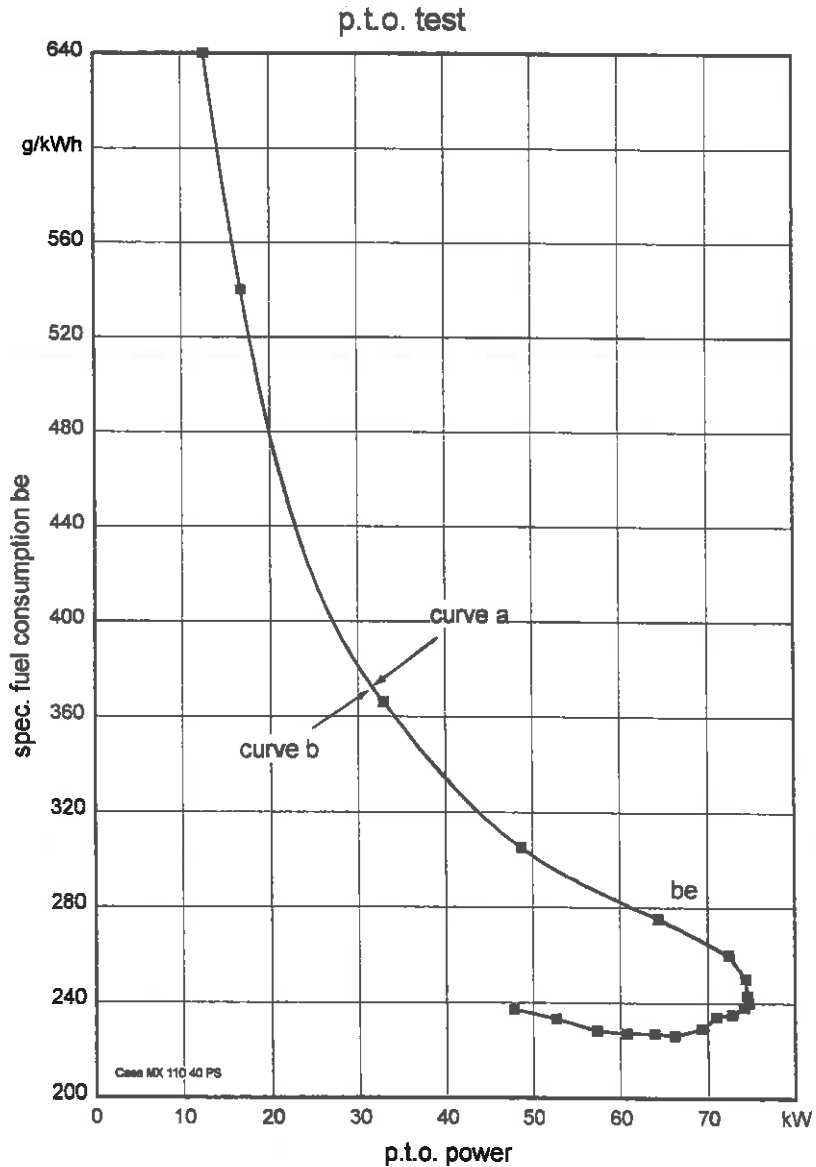

### 2 HYDRAULIC POWER AND LIFTING FORCE

Date of tests: 3rd June 1997

#### 2.1 Hydraulic power test

Sustained pressure with relief valve open

19.6 MPa

Pump delivery rate at minimum pressure

98.6 dm<sup>3</sup>/min

	Hydraulic power kW	Flow rate dm <sup>3</sup> /min	Pressure MPa	Oil Temperature °C
At 90% of the actual relief valve setting	15.3	52.0	17.6	65
Maximum	21.7	86.8	15.0	65

Tapping point used for test: at rear of tractor, connected with additional control valve no. 1, using control valves no 1 and no. 2 as return line.

#### 2.2 Power lift test. Maximum pressure in the lift cylinder 20.5 MPa

		At the hitch points				On the frame						
Height of lower hitch points above ground in down position		200 mm										
Vertical movement without lifting forces with lifting forces		755 mm				865 mm						
		730 mm				835 mm						
Max. corrected force exerted through full range		44.7 kN				35.25 kN						
Corresponding pressure		18.5 MPa										
Moment about rear axle						62.1 kNm						
Max. tilt angle of mast from vertical						7°						
Lifting heights relative to horizontal lower links												
mm	-465	-400	-300	-200	-100	0	+100	+200	+300	+330	+370	
Lifting forces at hitch points, corrected to 18.5 MPa												
kN		44.7	48.8	51.25	51.00	50.00	48.80	47.15	45.50	45.50		
Lifting forces at standard frame, corrected to 18.5 MPa												
kN	40.6	42.85	44.70	44.70	43.65	41.80	39.80	38.15	36.50		35.25	

### 2.3 Front power lift test. Maximum pressure in the lift cylinder 19.6 MPa

		At the hitch points	On the frame									
Height of lower hitch points above ground in down position		200 mm										
Vertical movement without lifting forces		710 mm	745 mm									
with lifting forces		695 mm	720 mm									
Max. corrected force exerted through full range		27.70 kN	21.25 kN									
Corresponding pressure		17.6 MPa										
Moment about front axle			40.80 kNm									
Max. tilt angle of mast from vertical			4°									
Lifting heights relative to horizontal lower links												
mm	-370	-360	-300	-200	-100	0	+100	+200	+300	+325	+360	
Lifting forces at hitch points, corrected to 17.6 MPa												
kN	32.20		31.05	30.15	29.50	29.25	29.05	28.35	27.70	27.70		
Lifting forces at standard frame, corrected to 17.6 MPa												
kN		34.75	31.95	29.70	28.15	26.80	25.55	24.20	22.50		21.25	

### 3 DRAWBAR POWER AND FUEL CONSUMPTION

Date of test: 26th and 27th May 1997  
 Type of track: Concrete

Gear and range	Speed km/h	Drawbar pull kN	Power kW	Engine speed rev/min	Slip of wheels %
<b>3.1 MAXIMUM POWER IN TESTED GEARS</b>					
I 1	2.53	67.05	47.1	2274	15.1
I 2	2.81	65.85	51.4	2092	15.0
I 3	3.58	58.61	58.3	1952	6.4
I 4	4.56	47.32	60.0	1949	3.9
II 1	5.68	38.99	61.5	1954	2.9
II 2	6.86	32.37	61.7	1951	2.3
II 3	8.49	26.44	62.3	1953	1.8
III 1	9.41	23.71	62.0	1953	1.8
II 4	10.57	20.91	61.4	1951	1.5
III 2	11.38	19.19	60.7	1953	1.4
<b>3.2 FUEL CONSUMPTION</b>					
<b>3.2.1 gear with max. drawbar power at rated speed</b>					
II 3	9.65	22.35	59.9	2202	1.4
<b>3.2.1.1 75 % of pull at maximum power at rated speed</b>					
II 3	10.17	16.76	47.3	2311	1.0
<b>3.2.1.2 50 % of pull at maximum power at rated speed</b>					
II 3	10.35	11.20	32.2	2343	0.7
<b>3.2.1.3 next higher gear at reduced engine speed; same pull and travelling speed</b>					
III 1	10.14	16.81	47.3	2086	1.2
<b>3.2.1.4 next higher gear at reduced engine speed; same pull and travelling speed</b>					
III 1	10.29	11.21	32.1	2107	0.8
<b>3.2.2 in selected gear nearest to 7,5 km/h at rated speed</b>					
II 2	7.77	27.64	59.7	2202	2.1
<b>3.2.2.1 75 % of pull at maximum power at rated speed</b>					
II 2	8.21	20.91	47.7	2311	1.5
<b>3.2.2.2 50 % of pull at maximum power at rated speed</b>					
II 2	8.35	13.96	32.4	2346	1.0
<b>3.2.2.3 next higher gear at reduced engine speed; same pull and travelling speed</b>					
II 3	8.24	20.79	47.6	1876	1.2
<b>3.2.2.4 next higher gear at reduced engine speed; same pull and travelling speed</b>					
II 3	8.40	13.88	32.4	1904	1.0

Height of drawbar above ground					Tyre inflation pressure		
430 mm					Front	Rear	
					80 kPa	80 kPa	
Specific fuel consumption g/kWh	Specific energy kWh/dm <sup>3</sup>	Temperatures			Atmospheric conditions		
		Fuel °C	Coolant °C	Engine oil °C	Temperature °C	Relative humidity %	Pressure kPa
404	2.10	67	84	98	17	56	100.4
361	2.35	61	82	96	18	56	100.4
308	2.75	68	89	102	16	56	100.4
297	2.85	67	86	102	16	56	100.4
292	2.90	66	88	100	16	56	100.4
293	2.89	62	86	100	13	60	100.4
289	2.93	64	85	99	13	60	100.4
291	2.91	65	88	101	14	60	100.4
294	2.88	66	87	99	15	58	100.4
294	2.89	66	86	99	16	56	100.4
314	2.70	68	84	99	18	56	100.4
356	2.38	57	85	101	20	52	100.4
425	1.99	64	82	99	20	52	100.4
as in 3.2.1.1							
326	2.60	66	84	98	20	52	100.4
as in 3.2.1.2							
386	2.19	64	82	97	20	52	100.4
317	2.66	61	86	98	19	52	100.4
360	2.35	65	84	99	19	52	100.4
425	1.99	65	82	97	18	52	100.4
as in 3.2.2.1							
300	2.82	65	83	96	19	52	100.4
as in 3.2.2.2							
354	2.39	66	82	96	18	52	100.4



CASE IH MX110 - MAXXUM (40 km/h), Power Shift

Test No. 97-159

4 REPAIRS AND REMARKS

None.



Published  
with the support of the Federal Ministry for Food, Agriculture and Forestry

**Deutsche Landwirtschafts-Gesellschaft e.V. (DLG)**  
**Fachbereich Landtechnik – Prüfungsabteilung –**  
**Eschborner Landstraße 122 (DLG-Haus)**  
**D-60489 Frankfurt am Main**