



**STÁTNÍ ZKUŠEBNA
ZEMĚDĚLSKÝCH,
POTRAVINÁŘSKÝCH
A LESNICKÝCH STROJŮ**

**SZZPLS
Třanovského 173
CZ-163 04 Praha 6 - Řepy
Czech Republic
Tel.: +420 2 3038111
Fax: +420 2 3015226**

**Report on test in accordance with the OECD Standard Code for the Official Testing of
Agricultural Tractor Performance**

CODE 2

Restricted Code

Date of approval: 20th November 1997

OECD No. 1708



Agricultural Tractor

ZETOR 6341 Super (4WD) 40 km/h version

**Manufactured by: ZETOR a.s., 632 00 Brno,
Czech Republic**

Report No. 13253

Date of test: August - September 1997



TABLE OF CONTENTS

1. SPECIFICATIONS OF TRACTOR	3
2. TEST CONDITIONS	17
3. COMPULSORY TEST RESULTS.....	20
3.1 Main power take-off	20
3.2 Hydraulic power and lifting force	24
3.3 Drawbar performance (unballasted tractor)	25
4. OPTIONAL TEST RESULTS	28
4.1 Braking	28
4.2 Measurement of external noise level.....	29
5. REPAIRS.....	29
6. REMARKS	29



Tractor manufacturer's name and address: ZETOR a.s., 632 00 Brno, Czech Republic
Location of tractor assembly: Brno, Czech Republic
Submitted for test by: The manufacturer
Selected for test by: The manufacturer
Place of running-in: Brno, Czech Republic
Duration of running-in: 65 hours
Location of test: SZZPLS Praha 6 - Řepy, Czech Republic

1. SPECIFICATIONS OF TRACTOR

1.1 IDENTIFICATION

Make: ZETOR
Model: 6341 Super 40 km/h version
Type: Wheeled, unit construction, all wheels drive
Number of driving wheels: 4
Serial No.: 001 001
1st Serial No.: 001 001

1.2 ENGINE

Make: ZETOR
Model: 7702
Type: 4-stroke diesel engine, direct injection, water cooled, naturally aspirated
Serial No.: *001001*

1.2.1 Cylinders

Number/disposition: 4, in-line, vertical
Bore/stroke: 102 mm/120 mm
Capacity: 3922 cm³
Compression ratio: 17.0:1
Arrangement of valves: Overhead
Cylinder liners: Wet, replaceable

1.2.2 Supercharging

None

1.2.3 Fuel system

Fuel feed system: Lift pump piston-type, integral with fuel injection pump



Make, model and type of fuel filters:	AUTOBRZDY, 443 741 111 001, one-stage with paper cartridge
Capacity of fuel tank:	120 dm ³
Make, model and type of injection pump:	MOTORPAL, 4M 3137, in-line
Serial No.:	BB 0017
Manufacturer's production setting of injection pump:	
Flow rate (rated engine speed and full load):	14.55+0.38 dm ³ /h
Timing:	25°+1° before TDC
Make, model and type of injection:	MOTORPAL, DOP 160 S 430-1436, 4 hole
Injection pressure:	18.6-0.8 MPa
1.2.4 Governor	
Make, model and type:	MOTORPAL, RV 3M 350/1100, centrifugal, variable speed
Governed range of engine speed:	From 700 to 2440 rev/min
Rated engine speed:	2200 rev/min
1.2.5 Air cleaner	
Make, model and type:	WOODGATE, WGCS 1175 or DONALDSON, FGL 08-0560, dry with paper primary and safety elements, integrated cyclon type pre-cleaner
Location of air intake:	Under bonnet forward of radiator
Maintenance indicator:	Indicator on air cleaner
1.2.6 Lubrication system	
Type of feed pump:	Gear
Type of filter:	Full flow with replaceable paper element
Number:	1
Oil cooler:	None
1.2.7 Cooling system	
Type of coolant:	Water and anti-freeze
Type of pump:	Centrifugal, belt driven
Specification of fan:	Axial, belt driven
Number of blades:	6
Fan diameter:	380 mm
Coolant capacity:	11.6 dm ³
Type of temperature control:	Thermostat
Superpressure system:	40±10 kPa



1.2.8 Starting system

Make, model and type: MAGNETON, 443 115 144 722, electrical, solenoid engaged

Starter motor power rating: 2.9 kW

Cold starting aid: None

Safety device: Gear change lever in neutral position

1.2.9 Electrical system

Voltage: 12 V, negative earth

Generator:

Make, model and type: MAGNETON, 443 113 516 673, alternator, belt driven

Power: 980 W

Battery (number of accumulators): 1

Rating: 135 Ah at 20 hours

1.2.10 Exhaust system

Make, model and type: ZETOR, 43.014.010, expansion and absorption muffler

Location: Left-hand side of engine, vertical

1.3 TRANSMISSION

1.3.1 Clutch

Make, model and type: ZETOR, 7901 1120, dry for travelling and p.t.o.

Number of plates: 2

Diameter of plates: 310 mm

Method of operation: Hydraulically by pedal

1.3.2 Gear box

Make, model and type: ZETOR, 53.122.000, mechanical

Arrangement: Synchromesh gear box with 5 forward and 1 reverse speeds, group gear box with two speed ranges (T and R)

Number of gears: 10 forward and 2 reverse (version fitted on the tested tractor)

Available options: Synchromesh gear box with torque multiplier with 20 forward and 4 reverse speeds or synchromesh gear box with reverser with 10 forward and 10 reverse speeds or synchromesh gear box with creeper with 20 forward and 4 reverse speeds

Oil cooler: None



1.3.3 Rear axle and final drives

Make, model and type: ZETOR, 53.161.000, crown wheel and bevel pinion differential and spur gear final drives

Differential lock:

Type: Dog clutch, electro-pneumatically activated

Method of engagement: Rocker switch on instrument panel

Method of disengagement: Service brake pedal

1.3.4 Front axle

Make, model and type: CARRARO, 20.14/164, crown wheel and bevel pinion differential and planetary final drives

Differential lock:

Type: Limited slip

Method of engagement: Self-engaging

Method of disengagement: Self-disengaging

1.3.5 Total ratios and travelling speeds (version fitted on the tested tractor)

Gear	Group	Number of engine revolutions for one revolution of the driving wheels	Nominal travelling speed at rated engine speed of 2200 rev/min km/h (*)
1	T	312.091	2.05
2		222.628	2.87
3		171.188	3.73
4		106.557	5.99
5		67.163	9.51
1	R	79.837	8.00
2		56.951	11.21
3		43.792	14.58
4		27.259	23.43
5		17.181	37.17
R	T	229.375	2.78
	R	58.677	10.88

(*) Calculated with a tyre dynamic radius index of 770 mm (ISO 4251/1-1992)

T: Turtle range, R: Rabbit range

Number of revolutions of front wheels for one revolution of rear-wheels: 1.3540



1.3.5 Total ratios and travelling speeds (optional - gear box with torque multiplier)

Gear	Group	Number of engine revolutions for one revolution of the driving wheels	Nominal travelling speed at rated engine speed of 2200 rev/min km/h (*)
1	TM	409.719	1.56
2		292.271	2.19
3		224.739	2.84
4		139.891	4.57
5		88.173	7.24
1	T	312.091	2.05
2		222.628	2.87
3		171.188	3.73
4		106.557	5.99
5		67.163	9.51
1	RM	104.812	6.09
2		74.767	8.54
3		57.491	11.11
4		35.786	17.85
5		22.556	28.31
1	R	79.837	8.00
2		56.951	11.21
3		43.792	14.58
4		27.259	23.43
5		17.181	37.17
R	TM	301.128	2.12
	T	229.375	2.78
	RM	77.033	8.29
	R	58.677	10.88

(*) Calculated with a tyre dynamic radius index of 770 mm (ISO 4251/1-1992)

T: Turtle range, R: Rabbit range, M: Torque multiplier engaged

Number of revolutions of front wheels for one revolution of rear-wheels: 1.3540



1.3.5 Total ratios and travelling speeds (optional - gear box with reverser)

Gear	Group	Number of engine revolutions for one revolution of the driving wheels	Nominal travelling speed at rated engine speed of 2200 rev/min km/h (*)
1	Forward T	312.091	2.05
2		222.628	2.87
3		171.188	3.73
4		106.557	5.99
5		67.163	9.51
1	Forward R	79.837	8.00
2		56.951	11.21
3		43.792	14.58
4		27.259	23.43
5		17.181	37.17
1	Reverse T	284.349	2.25
2		202.839	3.15
3		155.971	4.09
4		97.085	6.58
5		61.193	10.44
1	Reverse R	72.740	8.78
2		51.889	12.31
3		39.900	16.01
4		24.836	25.71
5		15.654	40.80

(*) Calculated with a tyre dynamic radius index of 770 mm (ISO 4251/1-1992)

T: Turtle range, R: Rabbit range

Number of revolutions of front wheels for one revolution of rear-wheels: 1.3540



1.3.5 Total ratios and travelling speeds (optional - gear box with creeper)

Gear	Group	Number of engine revolutions for one revolution of the driving wheels	Nominal travelling speed at rated engine speed of 2200 rev/min km/h (*)
1	TC	2637.243	0.24
2		1881.267	0.34
3		1446.580	0.44
4		900.435	0.71
5		567.547	1.13
1	RC	740.463	0.86
2		528.206	1.21
3		406.158	1.57
4		252.816	2.53
5		159.351	4.01
1	T	312.091	2.05
2		222.628	2.87
3		171.188	3.73
4		106.557	5.99
5		67.163	9.51
1	R	79.837	8.00
2		56.951	11.21
3		43.792	14.58
4		27.529	23.20
5		17.181	37.17
R	TC	1938.275	0.33
	RC	544.212	1.17
	T	229.375	2.78
	R	58.677	10.88

(*) Calculated with a tyre dynamic radius index of 770 mm (ISO 4251/1-1992)

T: Turtle range, R: Rabbit range, C: Creeper

Number of revolutions of front wheels for one revolution of rear-wheels: 1.3540

1.4 POWER TAKE-OFF

1.4.1 Main power take-off

Type: Independent

Method of engagement: Mechanically operated by hand lever or hydraulically by clutch pedal, through second plate in main clutch

Number of shafts: 1 (2 replaceable shaft ends)

Method of changing power take-off speeds: Manually by hand lever



1.4.1.1 Power take-off proportional to engine speed

Location: At rear of tractor

P.T.O.	Diameter of power take-off shaft end mm	Number of splines	In conformity with ISO 500/1991
540	34.9	6	Yes
1000	34.9	21	Yes

Height above ground: 777 mm

Distance from the median plane of the tractor: 0 mm

Distance behind rear-wheel axis: 263 mm

P.T.O.	P.T.O. speed rev/min	Engine speed rev/min	Ratio of rotation speeds (engine speed/p.t.o. speed)	Power restriction and maximum torque kW/Nm
540	540	1994	3.6923	None
	596	2200		
1000	1000	2050	2.0500	None
	1073	2200		

Direction of rotation (viewed from behind tractor): Clockwise

1.4.1.2 Power take-off proportional to ground speed

P.T.O. and range (*)	Travelling distance for one revolution of power take-off shaft m	Number of power take-off shaft revolutions for one revolution of (rear) driving wheels
T	0.118	41.0443
R	0.461	10.4997

(*) Independent of adjusting p.t.o. speed 540 or 1000 rev/min

T: Turtle range, R: Rabbit range

Direction of rotation with forward gear engaged (viewed from behind tractor): Clockwise

1.4.2 Optional power take-off (on request available, not fitted to tested tractor)

Type: Independent
 Method of engagement: Pneumatically operated by hand lever, through dry multiplate clutch
 Number of shafts: 1
 Method of changing power take-off speeds: None



1.4.2.1 Power take-off proportional to engine speed

Location: **At front of tractor**

P.T.O.	Diameter of power take-off shaft end mm	Number of splines	In conformity with ISO 500/1991
1000	34.9	21	Yes

Height above ground: **717 mm**

Distance from the median plane of the tractor: **0 mm**

Distance in front front-wheel axis: **590 mm**

P.T.O.	P.T.O. speed rev/min	Engine speed rev/min	Ratio of rotation speeds (engine speed/p.t.o. speed)	Power restriction and maximum torque kW/Nm
1000	1000	1818	1.8182	30.0/286.5
	1210	2200		

Direction of rotation (viewed from face tractor): **Clockwise**

1.4.2.2 Power take-off proportional to ground speed

None

1.5 POWER LIFT

Make, model and type: **ZETOR, 53.940.039, hydraulic with mechanical position, draft or mixed control, top link sensing**

Type of hydraulic system: **Open centre**

Type and number of cylinders: **1 integral single-acting and 2 external single-acting**

Type of linkage lock for transport: **Hydraulic**

Relief valve pressure setting (tolerance): **18.0+0.2 MPa**

Opening pressure of cylinder safety valve: **21.0+2.0 MPa**

Lift pump type: **Gear**

Transmission between pump and engine: **Gear driven from engine**

Type and number of filters: **1 full flow with replaceable paper element**

Site of oil reservoir: **Transmission housing**

Type, number and location of tapping points: **2 pressure and 1 return, quick release at rear of tractor**

Maximum volume of oil available to external cylinders: **20 dm³**



1.6 THREE-POINT LINKAGE

Category:

2, in conformity with ISO 730/1-1994

Category adapter:

None

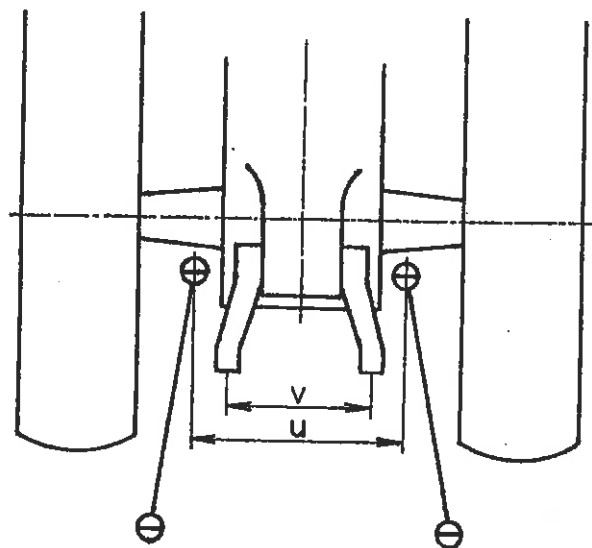
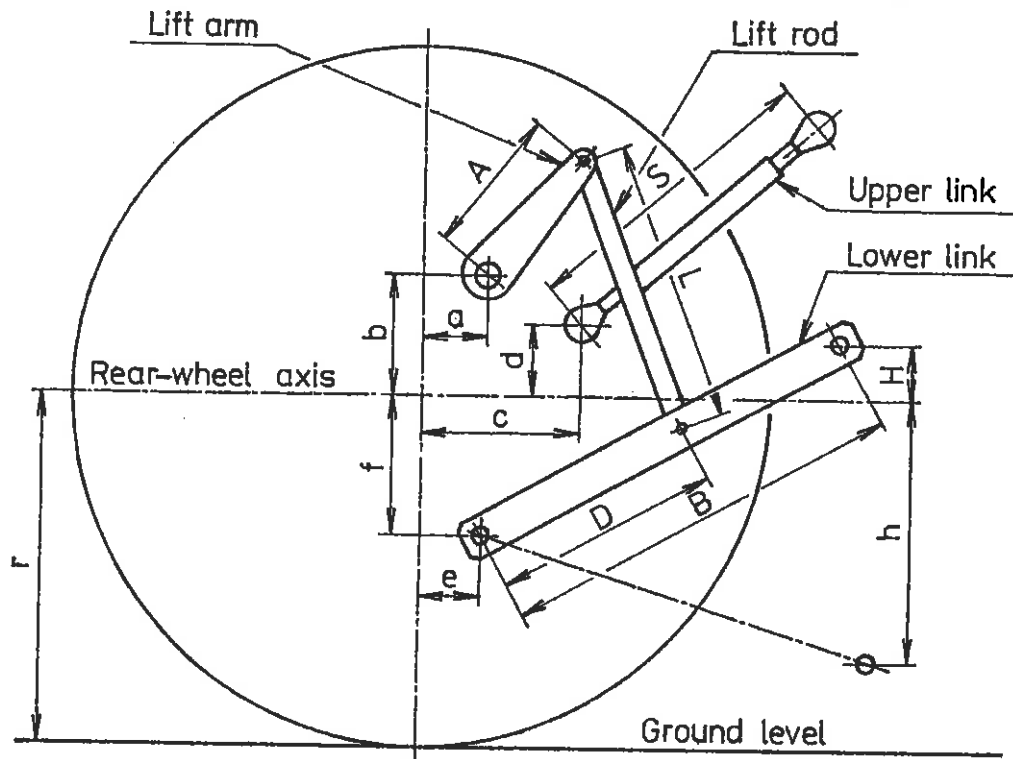



Linkage geometry dimensions:

		Dimension or range mm	Settings used in test mm
Length of lift arms	(A)	320	320
Length of lower links	(B)	861	861
Distance of lift arm pivot point from rear-wheel axis:	horizontally (a)	30	30
	vertically (b)	363	363
Horizontal distance between the 2 lower link points	(u)	450	450
Horizontal distance between the 2 lift arm end points	(v)	639	639
Length of upper link	(S)	550 to 760	678
Distance of upper link pivot point from rear-wheel axis:	horizontally (c)	288	288
	vertically (d)	182, 229, 276, 323	229
Distance of lower link pivot point from rear-wheel axis:	horizontally (e)	83	83
	vertically (f)	138	138
Distance of lower link pivot points to lift rod pivot points on lower links	(D)	402	402
Length of lift rods	(L)	442 to 572	555
Height of lower hitch points relative to the rear-wheel axis:	(h)	252 to 575	545
	(H)	121 to 372	145
Height above ground of lower hitch points when locked in transport position (*)		Any height withing lift range	

(*) Assuming the tyre dynamic radius index $r=745$ mm of ISO 4251/1-1992

1.7 SWINGING DRAWBAR

Type:	Clevis
Height above ground:	
Maximum:	512 mm
Minimum:	472 mm
Type of adjustment:	Inverting drawbar
Distance of hitch point from rear-wheel axis, horizontally:	652 and 658 mm
Distance of hitch point from power take-off shaft end:	
Vertically:	285 and 305 mm
Horizontally:	389 and 395 mm



Lateral adjustment (centre of clevis):	
Right-hand:	80 mm
Left-hand:	80 mm
Distance of pivot point from rear-wheel axis, horizontally:	93 mm to rear
Diameter drawbar pin hole:	31 mm
Maximum vertical permissible load:	12 kN

1.8 TRAILER HITCH

Type:	Automatic clevis
Hole diameter:	35 mm
Height above ground:	777, 827, 877, 927 and 9977 mm
Distance of hitch point from rear-wheel axis, horizontally:	628 mm
Distance of hitch point from power take-off shaft end:	
Vertically:	0, 50, 100, 150 and 200 mm
Horizontally:	365 mm
Maximum vertical permissible load:	10 kN

1.9 HOLED DRAWBAR (on request available, not fitted to tested tractor)

Number of holes:	7
Distance between holes:	80 mm
Hole diameter:	32 mm
Thickness/width of the drawbar:	2x20 mm/90 mm
Height above ground:	
Maximum:	915 mm
Minimum:	225 mm
Horizontal distance to power take-off shaft end (rear):	681 mm

1.10 SEMI-TRAILER HITCH

Type:	Towing hook
Hole diameter:	47 mm
Height above ground:	537 mm
Distance of hitch point from rear-wheel axis, horizontally:	368 mm
Distance of hitch point from power take-off shaft end:	
Vertically:	240 mm
Horizontally:	105 mm



Maximum vertical permissible load: 17 kN

1.11 FRONT TOWING HITCH

Height above ground: 739 mm

Diameter of pin hole: 31 mm

1.12 STEERING

Make, model and type: EATON, 261-1312-002 or DANFOSS, OSPC 100 ON or RCD-CALZONI, GIVI ON 100 G 125 or ZF, LAGC 100-1712-2, hydrostatic

Method of operation: Independent hydraulic circuit for steering

Pump: Gear, driven from engine

Ram: Double-acting cylinder on the front axle, simmetrical design

Working pressure: 12.5 MPa

1.13 BRAKES

1.13.1 Service brake

On the rear axle:

Make, model and type: KNOTT, 33.227.000, wet disc, multiplate, 4 discs on each side

Method of operation: Hydraulically by pedals, coupled or independent

On the front axle:

Make, model and type: CARRARO, 20.14/164, wet disc, 2 discs on each side

Method of operation: Hydraulically with air brake booster by coupled pedals

Trailer braking take-off: Combined one line and two line air braking system, operated by tractor pedals

1.13.2 Parking brake

Type: Common with service brake

Method of operation: Mechanically by hand lever with ratchet

1.14 WHEELS

Number:

Front: 2, steering and driving

Rear: 2, driving

Wheelbase: 2198 mm



Track width adjustment:

	Minimum mm	Maximum mm	Adjustment method
Front	1580	1810	Reversing wheels and off-set lug rims
Rear	1495	1795	Reversing wheels and off-set lug rims

1.15 PROTECTIVE STRUCTURE

Make, model and type:	ZETOR, UBK 7341, cab with integrated safety frame
Manufacturer's name and address:	ZETOR a.s., 632 00 Brno, Czech Republic
Protective device:	
Cab/frame/rollguard/other:	Cab
Tiltable/not tiltable:	Not tiltable
OECD approval number:	CSS 0404/9 with seat MARS Zetor 7211-5400 CSS 0404/10 with seat KAB XH2/U4 Fieldmaster CSS 0404/11 with seat KAB XH2/T6 Ploughmaster or seat GRAMMER DS 85H1/90A CSS 0404/12 with seat GRAMMER DS 85H/3A
Date of approval:	6th January 1997
Modification certificate if any:	None

1.16 SEAT**1.16.1 Driver's seat**

Make, model and type:	MARS, Zetor 7211-5400, upholstered seat
Type of suspension:	Parallelogram linkage adjustable for driver's weight
Type of damping:	Hydraulic
Range of adjustment:	
Longitudinal:	150 mm
Vertical:	60 mm

1.16.2 Optional driver's seat

Make, model and type:	KAB, XH2/U4 Fieldmaster or KAB, XH2/T6 Ploughmaster or GRAMMER, DS 85H1/90A or GRAMMER, DS 85H/3A, upholstered seat with back rest
Type of suspension:	Parallelogram linkage adjustable for driver's weight
Type of damping:	Hydraulic
Range of adjustment:	
Longitudinal:	150 mm



Vertical: 60 mm

1.16.3 Passenger seat

Location: Left-hand side of driver

Number of places: 1

1.17 LIGHTING

	Height above ground of centre mm	Size mm	Distance from outside edge of lights to median plane of tractor mm
Headlights	1280	145x80	195
Sidelights	1585	60x65	615
Rearlights	1690	140x40	800
Reflectors		Not fitted	

2. TEST CONDITIONS

2.1 OVERALL DIMENSIONS (unballasted tractor)

Length mm	Width		Height at top of	
	minimum mm	maximum mm	protective structure mm	exhaust silencer mm
3790	2005	2295	2690	2940

2.2 GROUND CLEARANCE (unballasted tractor): 441 mm

Clearance-limiting part: Differential of the front axle

2.3 TRACTOR MASS (unballasted tractor with cab)

	Without driver kg	With driver kg
Front	1480	1495
Rear	2220	2280
Total	3700	3775



2.4 TYRES AND TRACK WIDTH SPECIFICATIONS

	Front	Rear
Tyres:		
Make	TARUS	BARUM
Dimensions	13.6R24	18.4-34
Ply rating	121 A8	8 PR
Type	radial	diagonal
Maximum load (tyre manufacturer's)	14.50 kN	20.52 kN
Maximum load (tractor manufacturer's)	10.00 kN	17.00 kN
Inflation pressure (tyre manufacturer's)	160 kPa	140 kPa
Dynamic radius index	560 mm	770 mm
Chosen track width:	1580 mm	1495 mm

2.5 OILS AND LUBRICATION

2.5.1 Capacity and change interval

	Capacity dm ³	Oil change h	Filter change h
Engine	12.0	200	200
Gear box	64.0	1200	600
Front axle	5.5	1200	-
Rear axle		Common with gear box	
Final drive (front)	2x1.7	1200	-
Final drive (rear)	2x1.9	1200	-
Hydraulic system		Common with gear box	
Steering	2.5	1200	1200

2.5.2 Specifications

	Recommended	Used during test
Engine oil:		
Type	SAE 15W/40	As recommended
Viscosity	14.6 cSt at 100 °C	
Classification	API CF-4/SG	
Transmission oils:		
Type	SAE 80W	As recommended
Viscosity	7.5 cSt at 100 °C	
Classification	API GL-4	
Steering oil:		
Type	ARAL Vitam HF 32	As recommended
Viscosity	7.2 cSt at 100 °C	
Classification	ISO 6743 HF 32	



Hydraulic fluid: Same as transmission

2.5.3 Grease

Number of lubrication points: 26

2.6 FUEL

Type: Diesel fuel, in conformity with national standard
ČSN EN 590

Density at 15 °C: 0.842 g/cm³ for p.t.o. tests
0.838 g/cm³ for drawbar tests



3. COMPULSORY TEST RESULTS

3.1 MAIN POWER TAKE-OFF

Date and location of tests:

13th December 1996, SZZPLS Praha

Type of dynamometer:

FROUDE AG 400, eddy-current

Power	Speed		Fuel consumption			Specific energy
	Engine	P.T.O.	Hourly		Specific	
kW	rev/min		kg/h	l/h	g/kWh	kWh/l
3.1.1 MAXIMUM POWER - TWO-HOUR TEST						
46.9	2200	1073	12.38	14.70	264	3.19
3.1.2 POWER AT RATED ENGINE SPEED						
46.9	2200	1073	12.38	14.70	264	3.19
3.1.3 STANDARD POWER TAKE-OFF SPEED (1000±25 rev/min)						
45.2	2050	1000	11.58	13.75	256	3.29
3.1.4 PART LOADS						
3.1.4.1 the torque corresponding to maximum power at rated engine speed						
46.9	2200	1073	12.38	14.70	264	3.19
3.1.4.2 85 % of torque obtained in 3.1.4.1						
40.3	2224	1085	10.75	12.77	267	3.16
3.1.4.3 75 % of torque defined in 3.1.4.2						
30.9	2271	1108	8.77	10.42	284	2.97
3.1.4.4 50 % of torque defined in 3.1.4.2						
20.9	2302	1123	6.86	8.15	328	2.56
3.1.4.5 25 % of torque defined in 3.1.4.2						
10.6	2335	1139	5.12	6.08	483	1.74
3.1.4.6 unloaded						
-	2366	1154	3.57	4.24	-	-



Power	Speed		Fuel consumption			Specific energy
	Engine	P.T.O.	Hourly		Specific	
kW	rev/min		kg/h	l/h	g/kWh	kWh/l
3.1.5 PART LOADS AT STANDARD POWER TAKE-OFF SPEED 1000 rev/min						
3.1.5.1 the torque corresponding to maximum power						
45.2	2050	1000	11.58	13.75	256	3.29
3.1.5.2 85 % of torque obtained in 3.1.5.1						
41.0	2189	1068	10.59	12.58	258	3.26
3.1.5.3 75 % of torque defined in 3.1.5.2						
31.4	2237	1091	8.70	10.33	277	3.04
3.1.5.4 50 % of torque defined in 3.1.5.2						
21.3	2271	1108	6.84	8.12	321	2.62
3.1.5.5 25 % of torque defined in 3.1.5.2						
10.8	2306	1125	5.05	6.00	468	1.80
3.1.5.6 unloaded						
-	2333	1138	3.47	4.12	-	-

No load maximum engine speed: 2366 rev/min

Torque (equivalent crankshaft):

at maximum power: 203.6 Nm
 at rated engine speed: 203.6 Nm
 at standard power take-off speed: 210.6 Nm

Maximum torque (equivalent crankshaft): 236.0 Nm
 (engine speed: 1501 rev/min)

Mean atmospheric conditions:

Temperature: 23 °C
 Pressure: 96.1 kPa
 Relative humidity: 34 %

Maximum temperatures:

Coolant: 79 °C
 Engine oil: 102 °C
 Fuel: 40 °C
 Engine air intake: 28 °C



POWER TAKE-OFF TEST

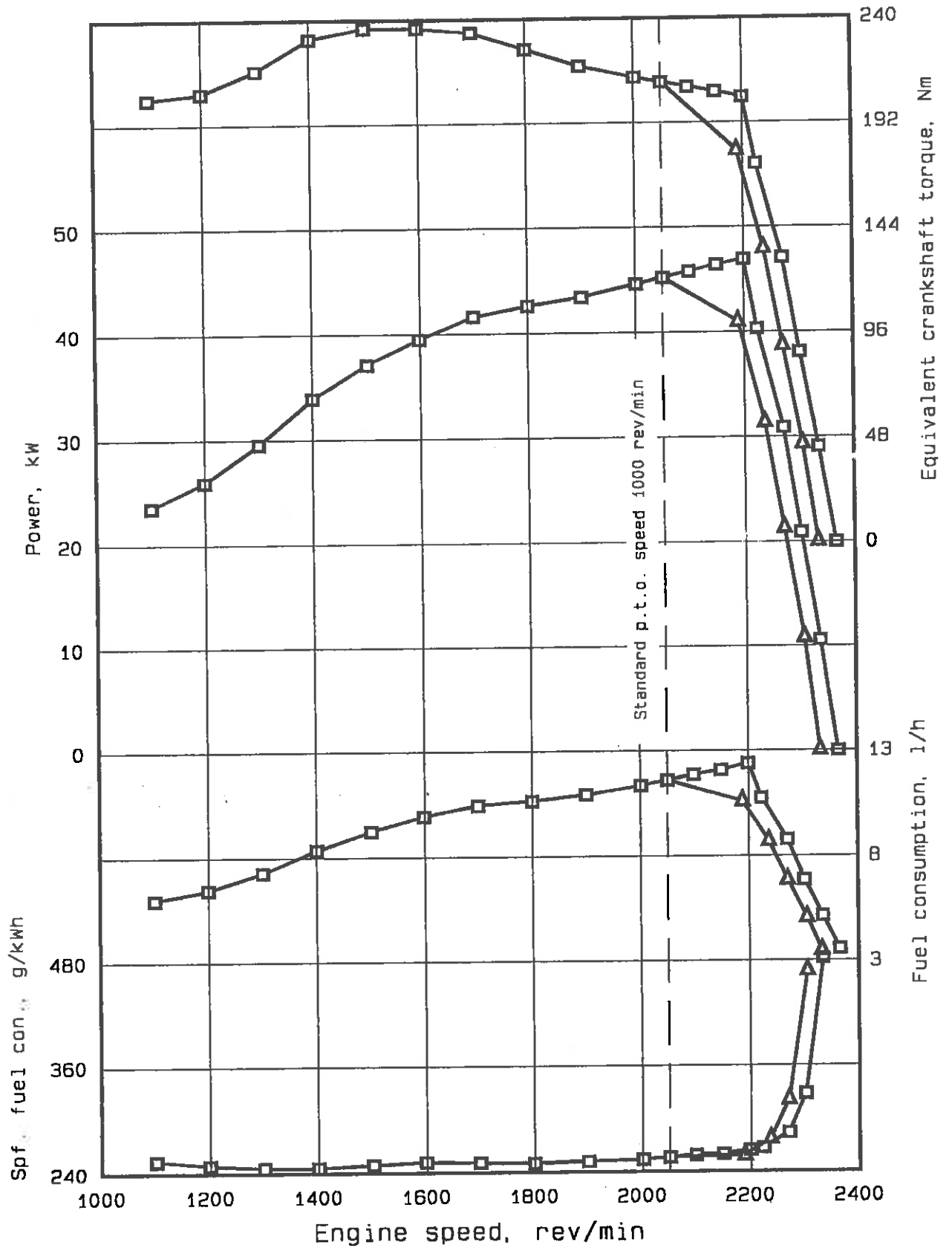



POWER TAKE-OFF TEST

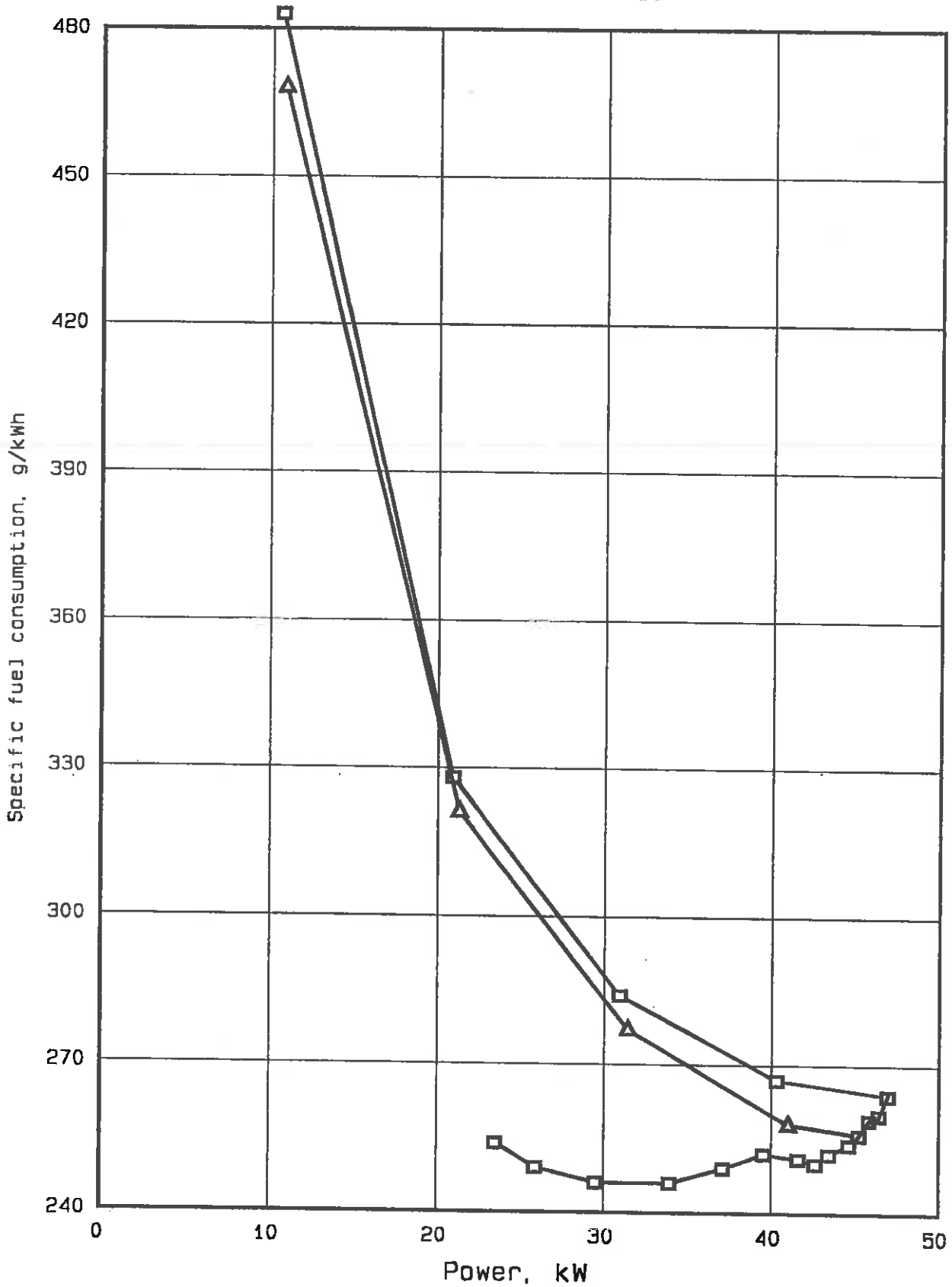



3.2 HYDRAULIC POWER AND LIFTING FORCE

Date of tests: 9th and 14 July 1997

3.2.1 Hydraulic power test

Sustained pressure with relief valve open: 18.0 MPa

Pump delivery rate at minimum pressure: 45.0 l/min

	Flow rate l/min	Pressure MPa	Power kW
Flow rate corresponding to a hydraulic pressure equivalent to 90 % of the actual relief valve pressure setting and corresponding hydraulic power	41.8	16.2	11.3
Flow rate and hydraulic pressure corresponding to maximum hydraulic power	41.8	16.2	11.3

Tapping point used for test: External tapping

Temperature of hydraulic fluid: 66 °C

Opening and closing pressures of the unloading valve: Not applicable

3.2.2 Power lift test

Linkage setting for test - see page 13

	At the hitch point	On the frame
Height of lower hitch points above ground in down position	200 mm	200 mm
Vertical movement	650 mm	864 mm
Maximum corrected force exerted through full range	35.1 kN	22.8 kN
Corresponding pressure of hydraulic fluid	16.2 MPa	16.2 MPa
Moment about rear-wheel axis	33.1 kNm	35.4 kNm
Maximum tilt angle of mast from vertical	-	11 degrees

Lifting heights relative to the horizontal plane including the lower link pivot points													
mm	-517	-500	-407	-400	-300	-200	-100	0	+100	+200	+243	+300	+347
Lifting forces at the hitch points, corrected to 16.2 MPa													
kN	-	-	46.1	45.8	44.3	42.1	39.9	38.0	36.7	35.6	35.1	-	-
Lifting forces at the test frame, corrected to 16.2 MPa													
kN	38.3	38.3	-	35.7	34.0	31.9	30.0	28.3	26.9	24.9	-	23.3	22.8



3.3 DRAWBAR PERFORMANCE (unballasted tractor)

Date of tests: 21st August 1997

Type of track: Bituminous-concrete surface

Height of drawbar above ground	Tyre inflation pressure	
	Front	Rear
512 mm	110 kPa	110 kPa



Gear and group	Power	Drawbar pull	Speed	Engine speed	Slip of wheels	Specific fuel consumption
	kW	kN	km/h	rev/min	%	g/kWh
3.3.1 MAXIMUM POWER IN TESTED GEARS						
2 T	21.9	30.1	2.62	2303	15.0	385
3 T	27.9	30.0	3.35	2275	14.9	358
4 T	37.2	23.9	5.61	2199	8.0	322
1 R	38.9	18.1	7.73	2195	4.8	306
5 T	37.8	14.5	9.38	2203	3.8	316
2 R	38.2	12.5	11.01	2204	2.9	312
3 R	37.0	9.2	14.47	2197	2.1	321
3.3.2 FUEL CONSUMPTION						
3.3.2.1 in selected gear, at maximum power at rated speed						
1 R	38.9	18.1	7.73	2195	4.8	306
3.3.2.1.1 75 % of pull at maximum power at rated speed						
1 R	30.7	13.6	8.13	2271	3.3	320
3.3.2.1.2 50 % of pull at maximum power at rated speed						
1 R	21.3	9.1	8.44	2308	2.0	363
3.3.2.1.3 next higher gear at reduced engine speed; same pull and travelling speed as in 3.3.2.1.1						
5 T	30.6	13.6	8.11	1916	3.3	300
3.3.2.1.4 next higher gear at reduced engine speed; same pull and travelling speed as in 3.3.2.1.2						
5 T	21.3	9.1	8.44	1945	2.0	334
3.3.2.2 in selected gear nearest to 7.5 km/h at rated speed						
1 R	38.9	18.1	7.73	2195	4.8	306
3.3.2.2.1 75 % of pull at maximum power at rated speed						
1 R	30.7	13.6	8.13	2271	3.3	320
3.3.2.2.2 50 % of pull at maximum power at rated speed						
1 R	21.3	9.1	8.44	2308	2.0	363
3.3.2.2.3 next higher gear at reduced engine speed; same pull and travelling speed as in 3.3.2.2.1						
5 T	30.6	13.6	8.11	1916	3.3	300
3.3.2.2.4 next higher gear at reduced engine speed; same pull and travelling speed as in 3.3.2.2.2						
5 T	21.3	9.1	8.44	1945	2.0	334



Specific energy	Temperature			Atmospheric conditions		
	Fuel	Coolant	Engine oil	Temperature	Relative humidity	Pressure
kWh/l	°C	°C	°C	°C	%	kPa
2.18	36	77	84	26	55	98.1
2.34	38	79	90	26	55	98.1
2.61	39	80	93	26	55	98.1
2.74	40	78	96	27	54	98.1
2.65	40	79	95	27	53	98.1
2.68	41	79	96	28	50	98.1
2.61	39	79	95	28	49	98.1
2.74	40	78	96	27	54	98.1
2.62	41	80	94	28	49	98.1
2.31	40	78	96	28	49	98.1
2.79	39	79	93	28	48	98.0
2.51	37	78	92	28	48	98.0
2.74	40	78	96	27	54	98.1
2.62	41	80	94	28	49	98.1
2.31	40	78	96	28	49	98.1
2.79	39	79	93	28	48	98.0
2.51	37	78	92	28	48	98.0



4. OPTIONAL TEST RESULTS

4.1 BRAKING

Date of tests:

26th August and 1st September 1997

	Tractor mass (with driver)			Speed before application of brakes km/h
	Front kg	Rear kg	Total kg	
Ballasted	2000	3400	5400	38.9
Unballasted	1495	2280	3775	40.0

4.1.1 Cold service braking device test (—————)

4.1.2 Fade test (-----)

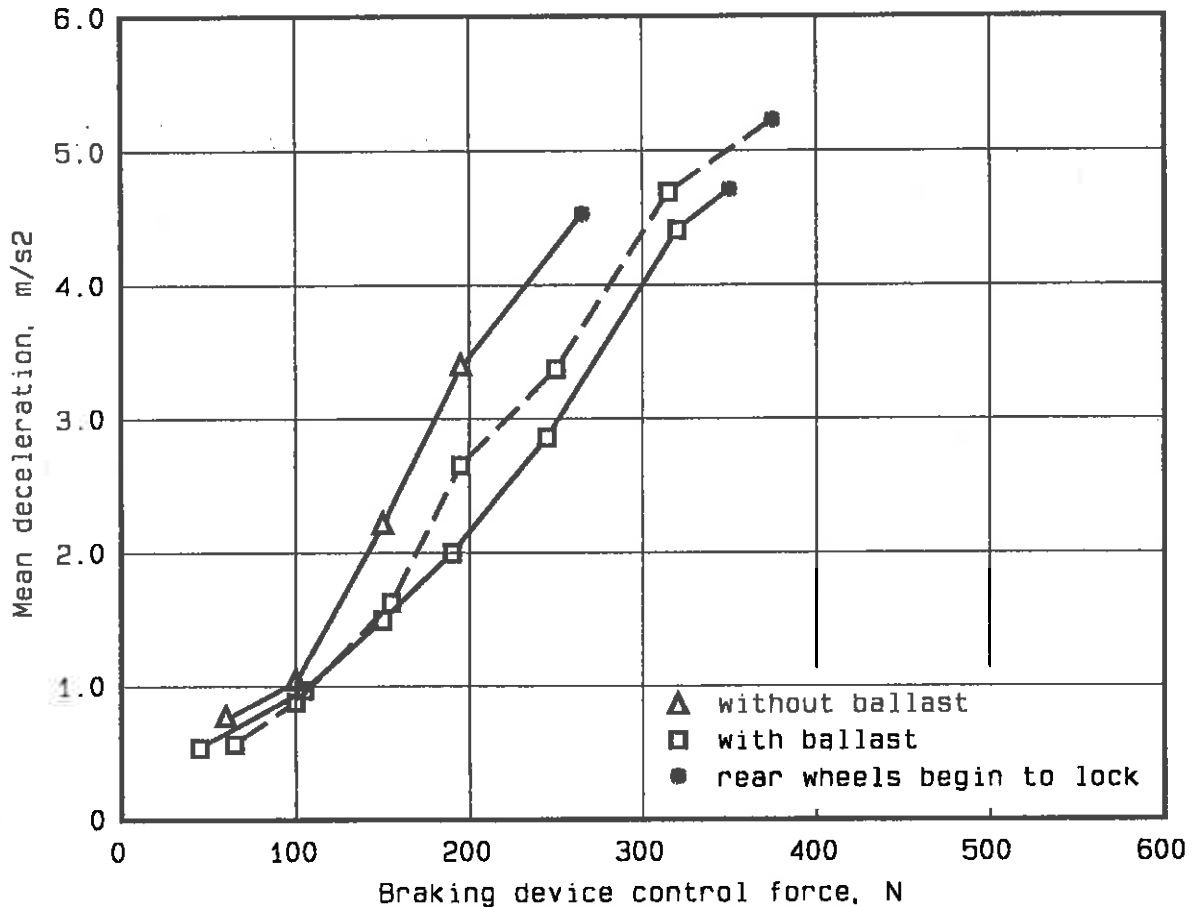

Maximum deviation of tractor from its original course:

Not significant

Abnormal vibration:

None

Brake heating method:

Driven with brakes applied for 1 km at 80 % of maximum speed with a pedal force corresponding to a deceleration of 1 m/s²

**4.1.3 Parking braking device test**

	Ballasted tractor on 18 % slope	
	Uphill	Downhill
Braking device control force	160 N	145 N

4.2 MEASUREMENT OF EXTERNAL NOISE LEVEL

Date of tests: 20th August 1997
Make and model of sound level meter: BRÜEL & KJAER, 2231
Type of track: Bituminous-concrete surface

4.2.1 According to OECD standard code 1

Gear number: 5 R
Travelling speed before acceleration: 30.0 km/h
Sound level: 87.0 dB(A)

4.2.2 According to EEC directives 74/151/EEC (Annex VI) and 88/410/EEC

Gear number: 5 R
Travelling speed before acceleration: 30.0 km/h
Sound level: 86.0 dB(A)

5. REPAIRS None

6. REMARKS None



Test carried out by:

Dipl. Ing. Peter Pernis

Head of the Tractor Laboratory

Handwritten signature of Peter Pernis in cursive script.

Dipl. Ing. Peter Pernis

Director

Handwritten signature of Vladimír Hanzlík in cursive script.

Dipl. Ing. Vladimír Hanzlík

